



Extracting High-Quality Nucleic Acid Made Easy with

Nexttractor[®] NX-Jr

Specifications

Individual cartridge

Sample input volume : 200 ~ 800 μ l

Elution volume : 50 ~ 150 μ l

Technical parameters

Power : 100 – 240 VAC, 3.0 – 1.5A, 50/60 Hz

Automatic door and UV sterilization

Heating range : room temperature ~ 100°C

Heating rate : 100°C / 5 minutes

Turnaround time

Up to 8 samples in a single run

in 15 – 30 minutes

(depends on sample type and protocol)

Dimension & Weight

205 mm(W) x 290 mm(D) x 295 mm(H) / 12 kg

User-friendly interface

Minimal training required for operation

Pre-programmed and customized protocols

4" LCD touch screen

Certification

ISO 13485 : 2016

CE

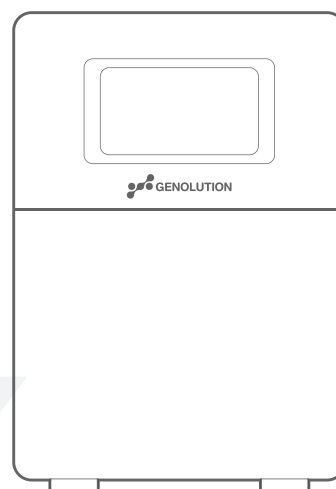

Nextractor Junior

Compact Innovation : NX-Jr Redefines Nucleic Acid Purification

Space-Saving Excellence :

NX-Jr combines compact size with outstanding performance, delivering unparalleled nucleic acid purification in a sleek and efficient design.

NX-Jr, the cutting-edge instrument for in vitro diagnosis, features three wash steps and customizable elution buffer volume.

Elevate Your Results :

Experience unrivaled purity of nucleic acids with NX-Jr, the ultimate tool for researchers dedicated to excellence.

Embrace Flexibility :

NX-Jr's unique ability to regulate the volume of elution buffer enables researchers to adapt and optimize their workflow, revolutionizing their in vitro diagnosis processes.

Elevate Your Research :

With NX-Jr as your trusted companion, experience elevated results and unrivaled purity of nucleic acids. This advanced instrument empowers researchers who strive for excellence, ensuring that their diagnostic research meets the highest standards of quality and accuracy.

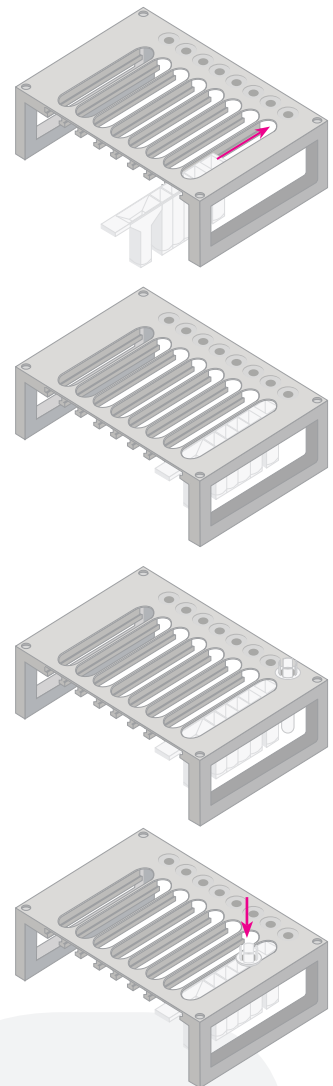

Features

Fine-Tune Your Research :

Tap into the power of customization with our instrument's exceptional elution buffer volume flexibility. Within the range of 50 - 150 μ l, you have the freedom to fine-tune and optimize your diagnostic protocols, ensuring optimal conditions for nucleic acid extraction and purification.

Empower Your Discoveries :

With our instrument's customizable elution buffer volume range of 50 - 150 μ l, you have the power to push the boundaries of in vitro diagnosis. Unlock new possibilities, discover novel insights, and pave the way for groundbreaking advancements that have the potential to transform the field.

Maximize Efficiency, Minimize Waste :

We understand the importance of efficiency in the laboratory. With our instrument's customizable elution buffer volume, you can streamline your workflow and minimize waste by precisely selecting the optimal volume between 50 - 150 μ l, eliminating unnecessary usage and optimizing resource allocation.

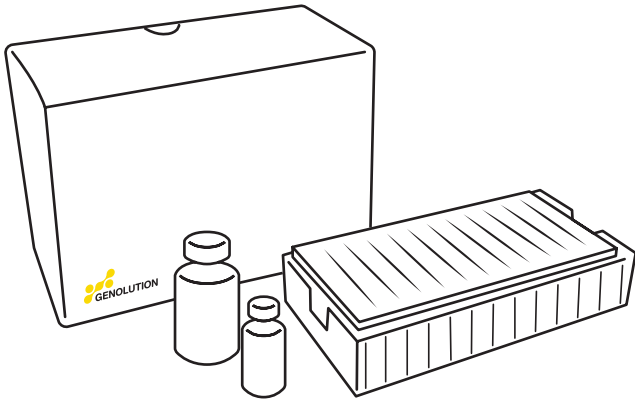

In summary, our in vitro diagnostic instrument offers unparalleled customization through its customizable elution buffer. With precise control over your experimental parameters, you can fine-tune your protocols, achieve reliable and consistent results, maximize efficiency, and unlock new possibilities in the field of diagnostic research.

Cartridge

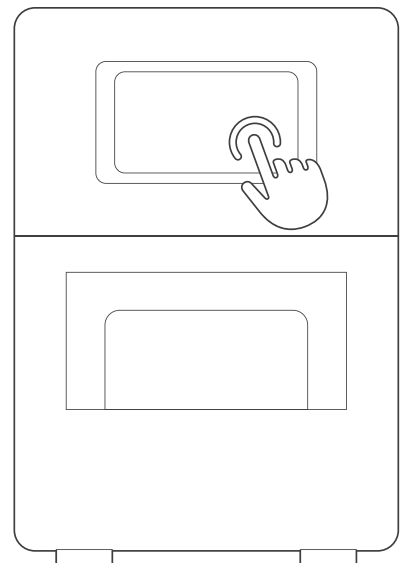
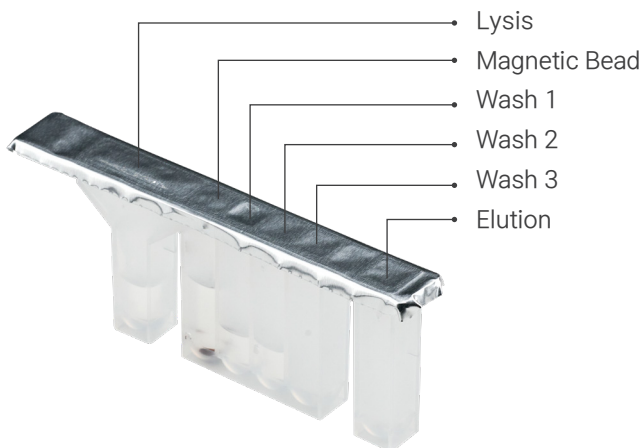



GENOLUTION

Nextractor Junior

User Interface

1. Home



EXTRACTION

Pressing the EXTRACTION button on the NX-Jr 'Home' screen will begin the process of preparing an extraction method run on the NX-Jr product.

DOOR OPEN

This button will open the front automatic sliding door.

STERILIZATION

Pressing the STERILIZATION button activates the UV light in the NX-Jr product for the time specified in the administrator settings.

2. Sterilization

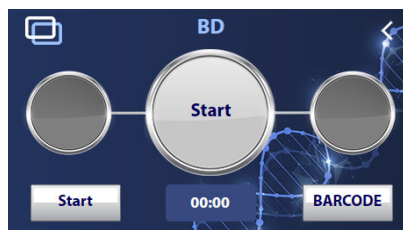

One customizable aspect of the sanitization process is the UV function time.

Users have the flexibility to set the duration of the UV function according to their specific requirements. This allows for effective disinfection and ensures that any potential contaminants on the instrument are neutralized.

By strictly following the guidelines and restrictions, and utilizing the adjustable UV function time, the instrument can be thoroughly sanitized, minimizing the risk of cross-contamination and maintaining the integrity of the extracted nucleic acid samples. Functions that are not allowed during sanitization include opening the door and running an extraction.

3. Protocol



By touching the appropriate protocol on the instrument's interface, users can select the specific instructions and parameters required for the extraction process.

Once a protocol is modified according to the specific needs or preferences of the user, it is automatically saved within the instrument's memory. This eliminates the need to set up the modified protocol each time the instrument is used.

Each protocol is modified with the aim of achieving the best efficiency. By customizing the protocol to suit the particular requirements of the nucleic acid extraction, users can optimize the extraction efficiency and improve the quality of the extracted nucleic acid samples.

How to use

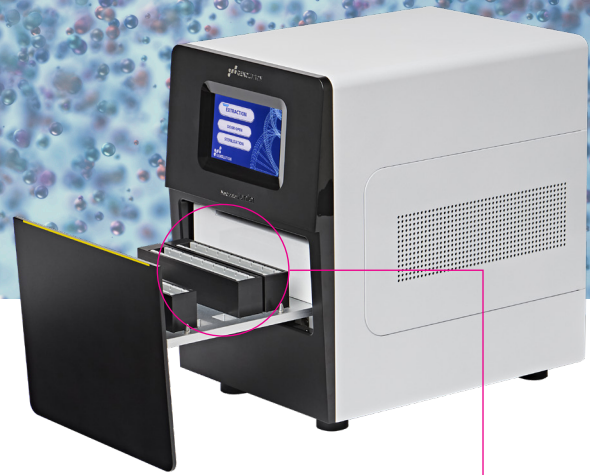

Heating Block

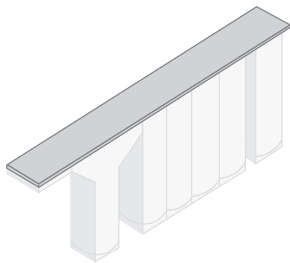

1. Prepare the sealed cartridge

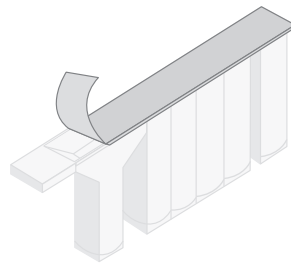

2. Carefully remove the attached seal

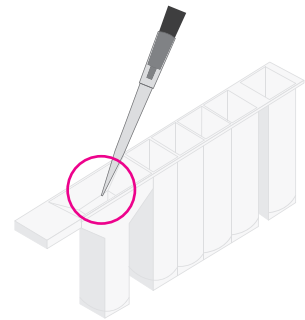

3. Inject the sample into the lysis compartment

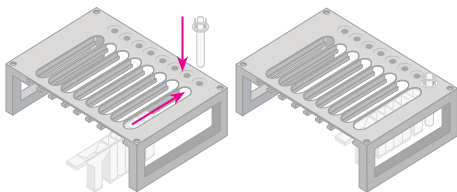

4. Insert the strip and cartridge all the way into the cartridge adapter

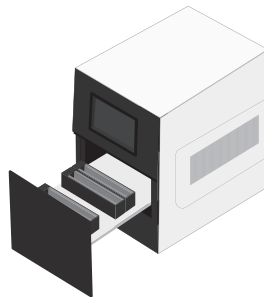

5. Press the door open button

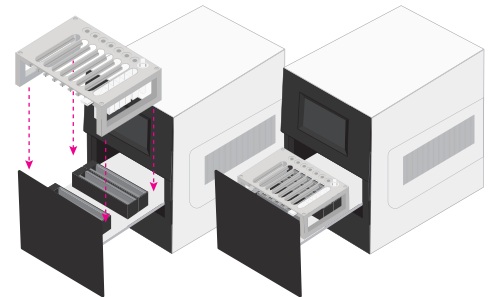

6. Fasten the cartridge adapter to the instrument

Nextractor[®] NX-48N

Dimension

385 mm(W) x 390 mm(D) x 400 mm(H)
/ 25 kg

Samples per run

1 - 48 samples in 15 - 30 minutes

Reagents

Pre-filled reagents
with various package sizes

User interface

7" LCD touch screen

Heating range

Room temperature ~ 100°C



Nextractor NX-Duo

560 mm(W) x 580 mm(D) x 457 mm(H)
/ 60 kg

24 / 96 samples in 15 - 30 minutes

Pre-filled reagents

6" LCD touch screen

Room temperature ~ 100°C



63, Magokjungang 8-ro 3-gil, Gangseo-gu, Seoul, Korea 07793
T +82 2-449-8670 F +82 2-449-8671
www.genolution.co.kr

Inquiries
sales@genolution1.com